

PRODUCT NAME

CHICK DRINKER 1 l

REFERENCE

10919

MAIN FEATURES

MATERIAL

POLYPROPYLENE

COLOR

GREEN LEMON - WHITE

WEIGHT

0,100 kg

TYPE OF CLOSURE

TURN

ACCESORIES



SKETCH

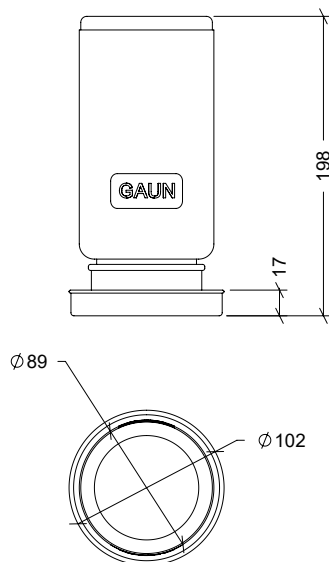

SPARE PARTS

N°	DESCRIPTION
1	TANK
2	BASE

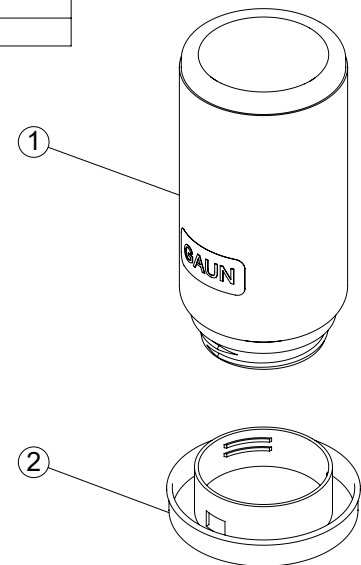

PACKAGING CHARACTERISTICS

PACKAGE TYPE

CARDBOARD BOX

QUANTITY

10 PIECES

DIMENSIONS

465x240x200 mm

WEIGHT

1,380 kg

VOLUME

0,022 m³

EURO PALLET

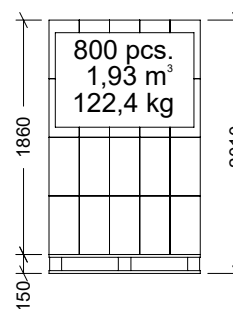

AMERICAN PALLET

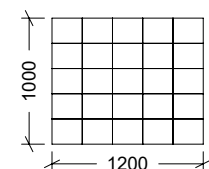
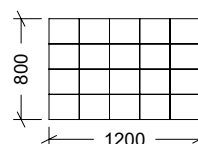
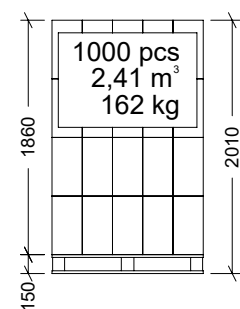

EURO PALLET WEIGHT: 12 kg

AMERICAN PALLET WEIGHT: 24 kg