

NOMBRE

REFERENCIA

BEBEDERO AVES ECO 1,5 LITROS CON PATAS - PISTACHO

10933

CARACTERÍSTICAS DE PRODUCTO

MATERIAL

POLIPROPILENO

COLOR

BLANCO-PISTACHO

PESO

0,160 kg

TIPO DE CIERRE

GIRO

ACCESORIOS



CROQUIS

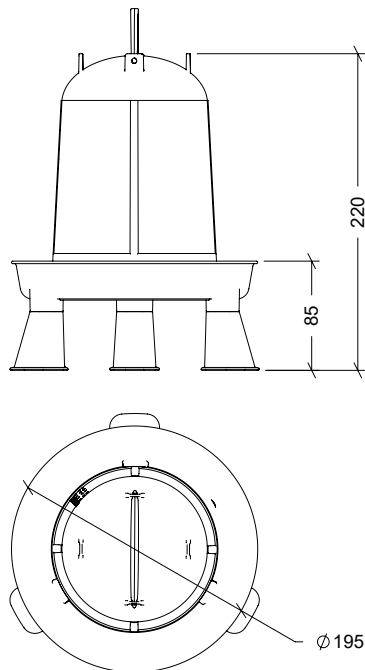

DESPIECE

Nº	DESCRIPCIÓN
1	ASA
2	BIDÓN
3	PLATO
4	PATAS

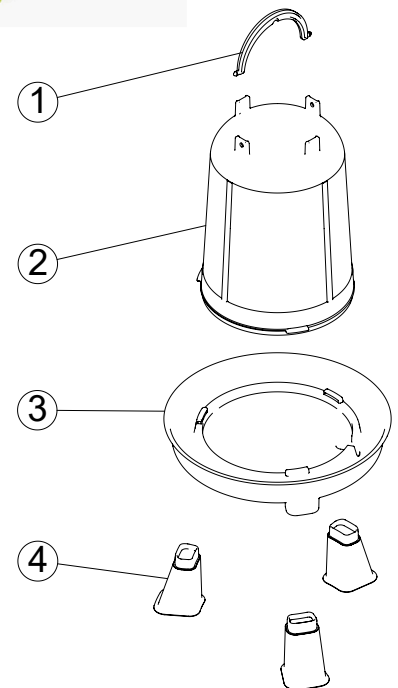

CARACTERÍSTICAS DE EMBALAJE

TIPO DE PACKING

CAJA

CANTIDAD

10 Unidades

DIMENSIONES

330×255×295 mm

PESO

1,85 kg

VOLUMEN

0,025 m³

PALET EUROPEO

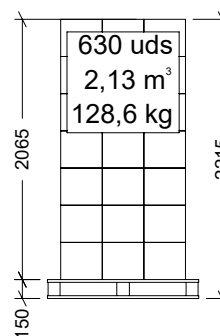

PALET AMERICANO

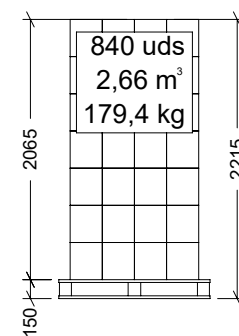

PESO PALET EUROPEO: 12 kg

PESO PALET AMERICANO: 24 kg

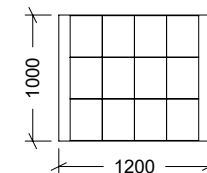
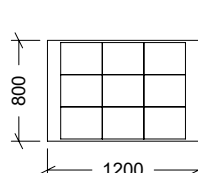

Cotas en mm