

NOMBRE

BEBEDERO PREMIUM 8 l (ORO)

REFERENCIA

11052

CARACTERÍSTICAS DE PRODUCTO

MATERIAL

POLIPROPILENO

COLOR

DORADO - BLANCO

PESO

0,615 kg

TIPO DE CIERRE

GIRO

ACCESORIOS



CROQUIS

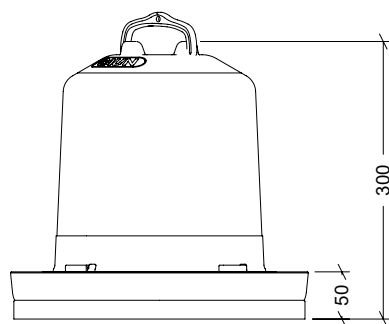

DESPIECE

Nº	DESCRIPCIÓN
1	BASE
2	BIDÓN
3	ASA

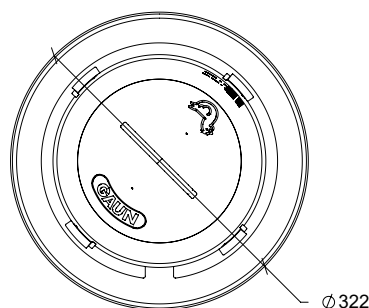
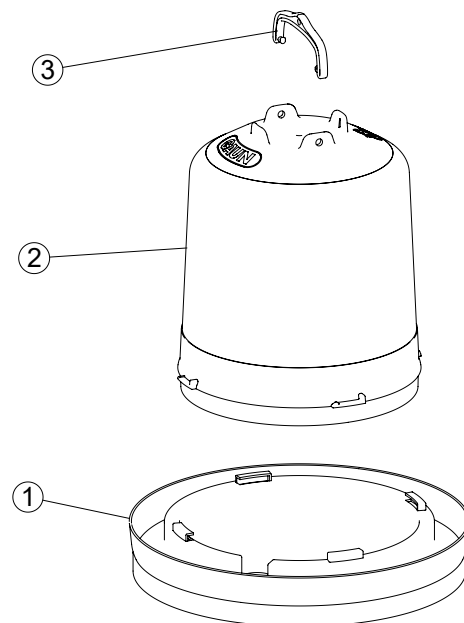

CARACTERÍSTICAS DE EMBALAJE

TIPO DE PACKING

CAJA

CANTIDAD

5 Unidades

DIMENSIONES

325x325x610 mm

PESO

4,000 kg

VOLUMEN

0,064 m³

PALET EUROPEO

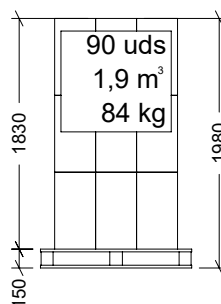

PALET AMERICANO

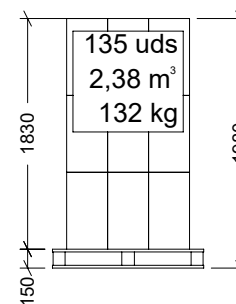

PESO PALET EUROPEO: 12 kg

PESO PALET AMERICANO: 24 kg

