

NOMBRE

**BEBEDERO PREMIUM 12 l (VERDE)**

REFERENCIA

**11056**

**CARACTERÍSTICAS DE PRODUCTO**

MATERIAL

POLIPROPILENO

COLOR

VERDE - BLANCO

PESO

0,735 kg

TIPO DE CIERRE

GIRO

ACCESORIOS



CROQUIS

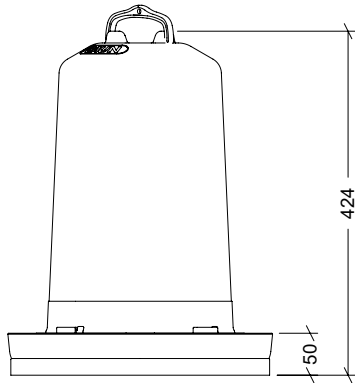

DESPIECE

Nº	DESCRIPCIÓN
1	BASE
2	BIDÓN
3	ASA

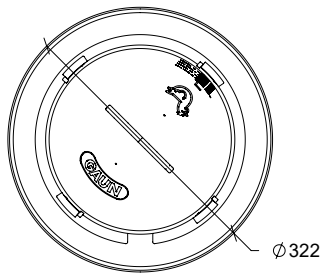
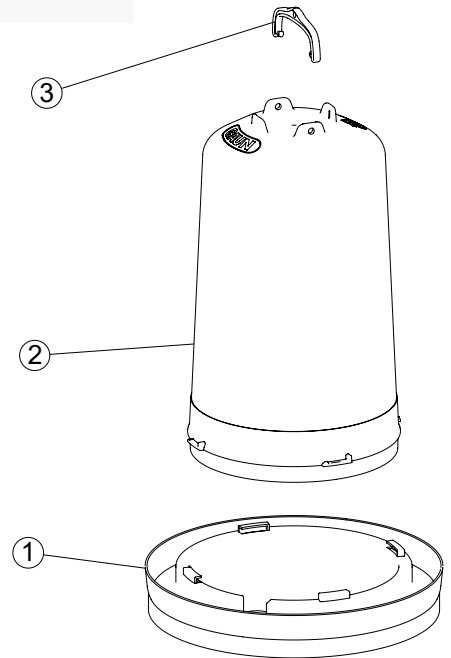

**CARACTERÍSTICAS DE EMBALAJE**

TIPO DE PACKING

CAJA

CANTIDAD

5 Unidades

DIMENSIONES

325x320x655 mm

PESO

4,560 kg

VOLUMEN

0,068 m<sup>3</sup>

PALET EUROPEO

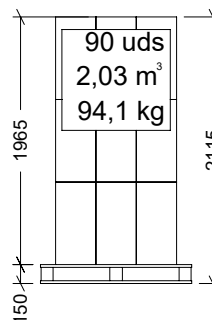

PALET AMERICANO

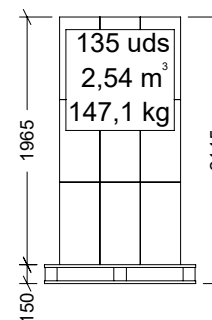

**PESO PALET EUROPEO: 12 kg**

**PESO PALET AMERICANO: 24 kg**

