

NOMBRE

**COMEDERO POLLITOS 1 kg**

REFERENCIA

**11215**

**CARACTERÍSTICAS DE PRODUCTO**

MATERIAL

POLIPROPILENO

COLOR

PISTACHO - BLANCO

PESO

0,161 kg

TIPO DE CIERRE

GIRO

ACCESORIOS



CROQUIS

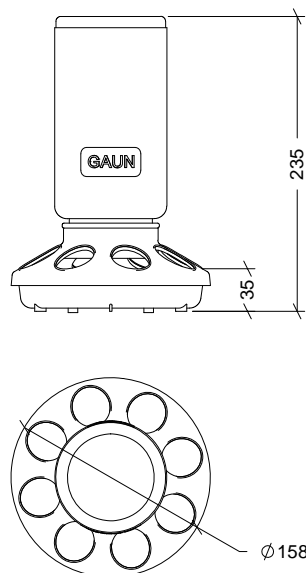

DESPIECE

Nº	DESCRIPCIÓN
1	BOTELLA
2	ANILLO ANTIDESPERSION
3	PLATO

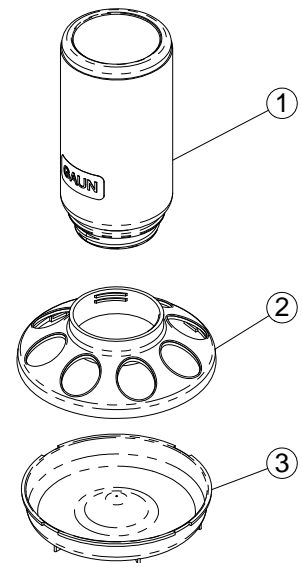

**CARACTERÍSTICAS DE EMBALAJE**

TIPO DE PACKING

CAJA

CANTIDAD

10 Unidades

DIMENSIONES

555x305x280 mm

PESO

2,100 kg

VOLUMEN

0,047 m<sup>3</sup>

PALET EUROPEO

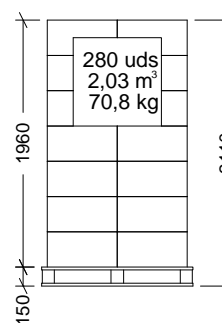

PALET AMERICANO

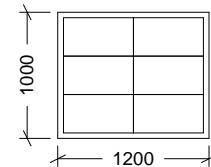
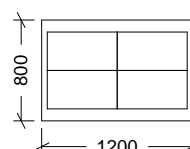
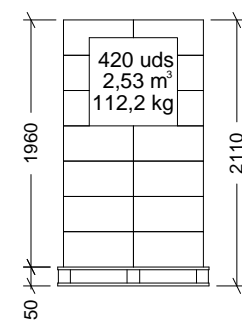

**PESO PALET EUROPEO: 12 kg**

**PESO PALET AMERICANO: 24 kg**