

NOMBRE

**TOLVA AVES PLÁSTICO RECICLADO 4 KGS. CON PATAS**

REFERENCIA

**11238**

**CARACTERÍSTICAS DE PRODUCTO**

MATERIAL

POLIPROPILENO RECICLADO

COLOR

MEZCLA ALEATORIA

PESO

0,610 kg

TIPO DE CIERRE

PRESIÓN

ACCESORIOS

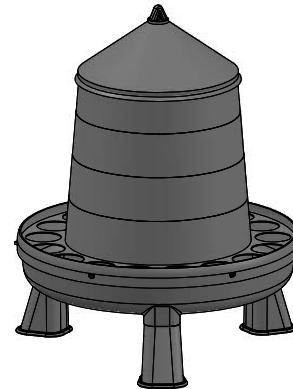

CROQUIS

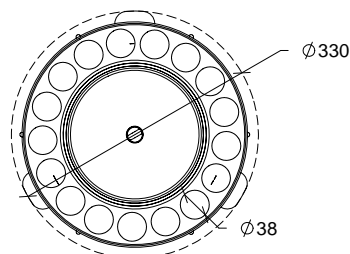
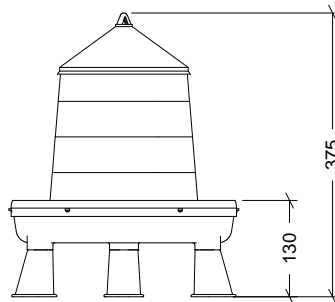

DESPIECE

Nº	DESCRIPCIÓN
1	TAPA
2	CONO
3	PLATO
4	PATA

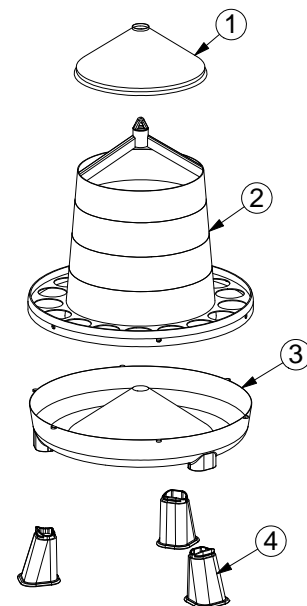

**CARACTERÍSTICAS DE EMBALAJE**

TIPO DE PACKING

CAJA

CANTIDAD

10 Unidades

DIMENSIONES

305x305x730 mm

PESO

6,420 kg

VOLUMEN

0,068 m<sup>3</sup>

PALET EUROPEO

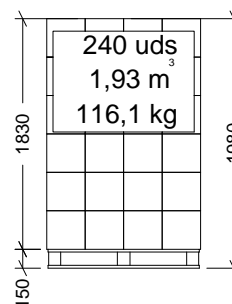

PALET AMERICANO

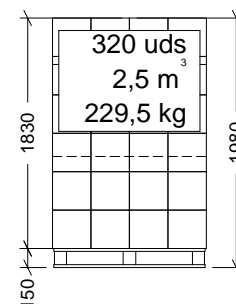

**PESO PALET EUROPEO: 12 kg**

**PESO PALET AMERICANO: 24 kg**

