

NOMBRE

TOLVA AVES BIO 4 KGS.

REFERENCIA

11244

CARACTERÍSTICAS DE PRODUCTO

MATERIAL

POLIETILENO BIOBASADO

COLOR

BLANCO - AMARILLO

PESO

0,537 kg

TIPO DE CIERRE

PRESIÓN

ACCESORIOS

CUERDA Y FRENO

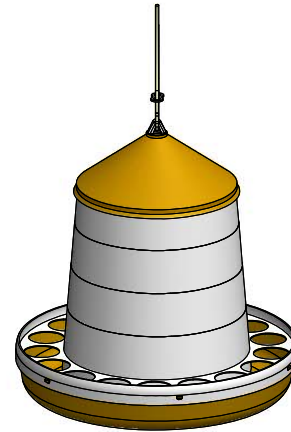

CROQUIS

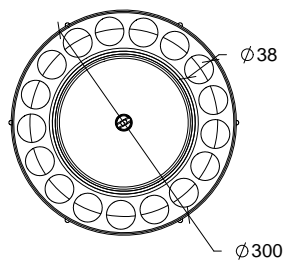
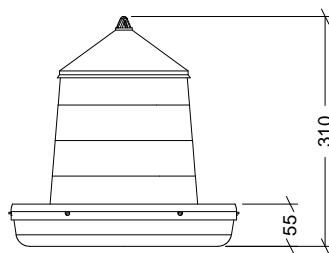

DESPIECE

Nº	DESCRIPCIÓN
1	TAPADERA
2	CONO
3	PLATO

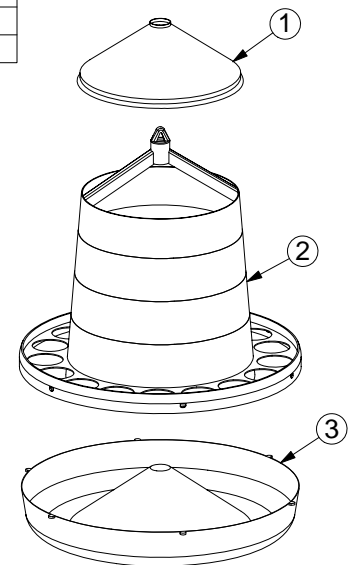

CARACTERÍSTICAS DE EMBALAJE

TIPO DE PACKING

CAJA

CANTIDAD

10 Unidades

DIMENSIONES

310x310x770 mm

PESO

6,080 kg

VOLUMEN

0,074 m³

PALET EUROPEO

PALET AMERICANO

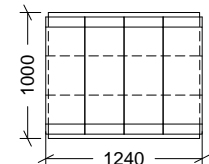
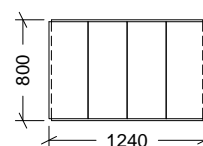
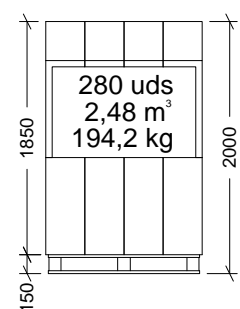
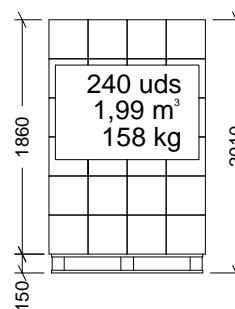

PESO PALET EUROPEO: 12 kg

PESO PALET AMERICANO: 24 kg