

NOMBRE

TOLVA AVES BIO 4 KGS. CON PATAS

REFERENCIA

11249

CARACTERÍSTICAS DE PRODUCTO

MATERIAL

POLITILENO BIOBASADO

COLOR

BLANCO - AMARILLO

PESO

0,610 kg

TIPO DE CIERRE

PRESIÓN

ACCESORIOS

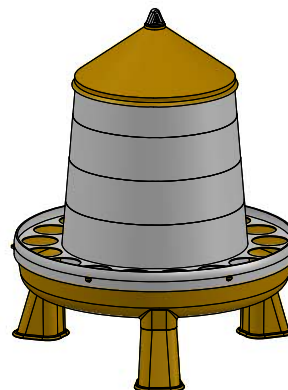

CROQUIS

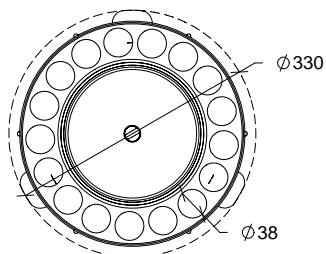
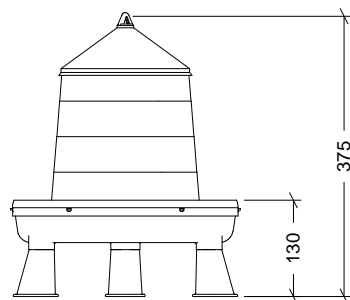

DESPIECE

Nº	DESCRIPCIÓN
1	TAPA
2	CONO
3	PLATO
4	PATA

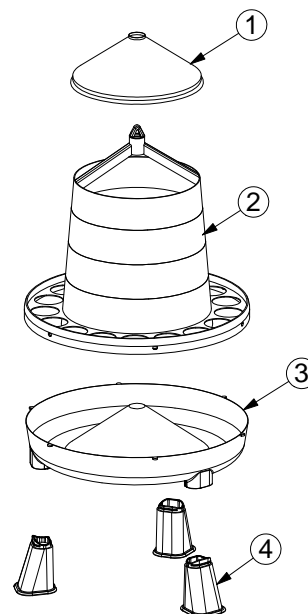

CARACTERÍSTICAS DE EMBALAJE

TIPO DE PACKING

CAJA

CANTIDAD

10 Unidades

DIMENSIONES

305x305x730 mm

PESO

6,420 kg

VOLUMEN

0,068 m³

PALET EUROPEO

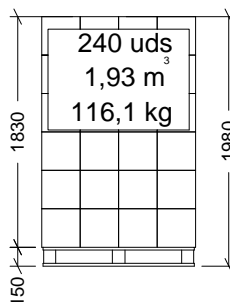

PALET AMERICANO

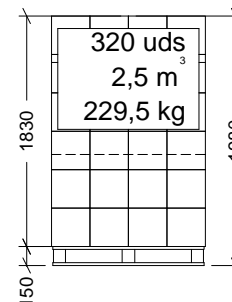

PESO PALET EUROPEO: 12 kg

PESO PALET AMERICANO: 24 kg

