

NAME

**MINI AUTOMATIC DRINKER FOR RABBITS**

REFERENCE

**24620**

**PRODUCT FEATURES**

MATERIAL

POLYPROPYLENE / STAINLESS STEEL

COLOR

GREEN - STEEL

WEIGHT

0,050 kg

CLOSING SYSTEM

PRESSURE

ACCESSORIES



SKETCH

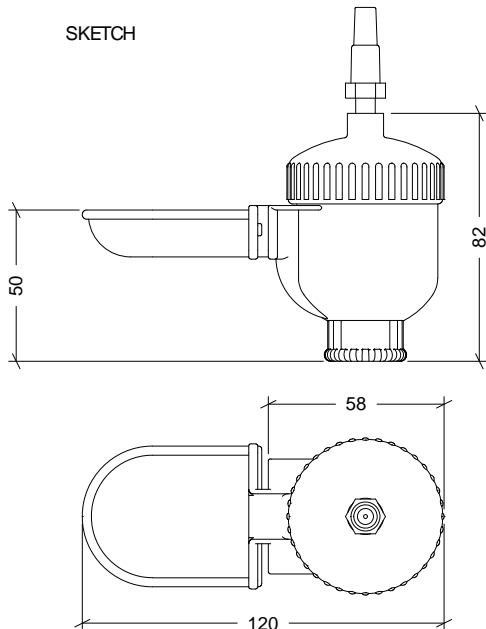

EXPLODED VIEW

Nº	DESCRIPTION
1	WATER TUBE CONNECTOR
2	LID
3	RUBBER
4	FLOAT
5	FLOAT FILTER
6	DRINKER BODY
7	CAP

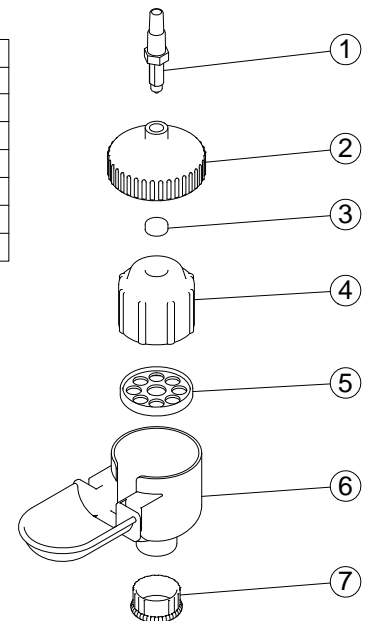

**PACKING FEATURES**

PACKAGING TYPE

BOX

QUANTITY

20 PIECES

DIMENSION

300x250x220 mm

WEIGHT

1,550 kg

VOLUME

0,017 m<sup>3</sup>

EURO PALLET

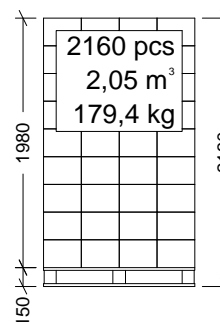

AMERICAN PALLET

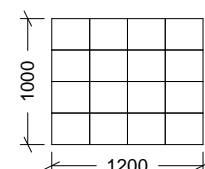
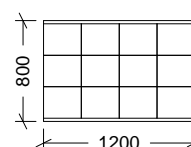
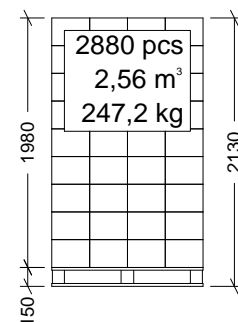

**WEIGHT EURO PALLET: 12 kg**

**WEIGHT AMERICAN PALLET: 24 kg**