

NOMBRE

REFERENCIA

BEBEDERO POLLITOS 2 LITROS - AZUL

10907

CARACTERÍSTICAS DE PRODUCTO

MATERIAL

POLIPROPILENO

COLOR

AZUL

PESO

0,197 kg

TIPO DE CIERRE

GIRO

ACCESORIOS

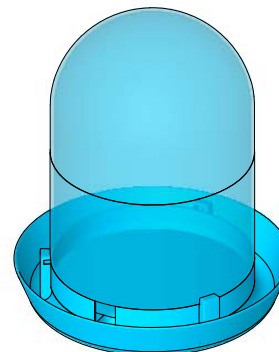

CROQUIS

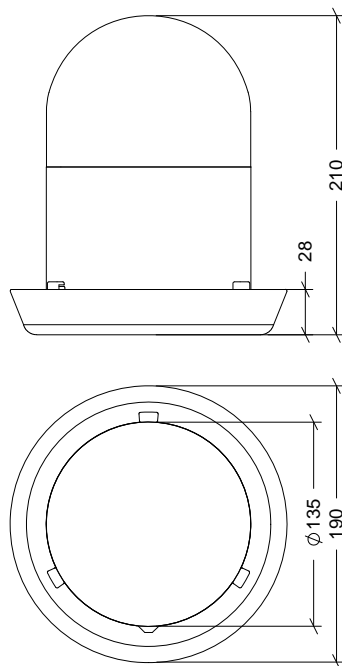

DESPIECE

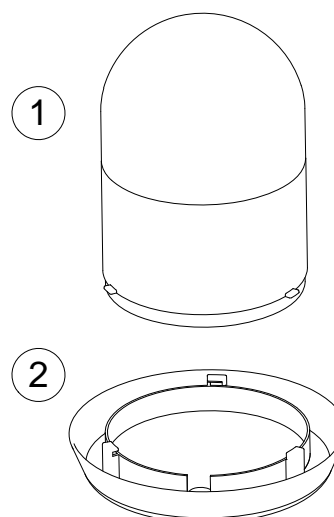

Nº	DESCRIPCIÓN
1	BIDÓN
2	PLATO

CARACTERÍSTICAS DE EMBALAJE

TIPO DE PACKING

CAJA

UNIDADES/PACKING

10 Unidades

DIMENSIONES PACKING

465×285×310 mm

PESO PACKING

2,420 kg

VOLUMEN PACKING

0,041 m³

PALET 0,60x1,00 m

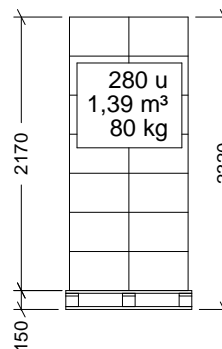

PALET AMERICANO

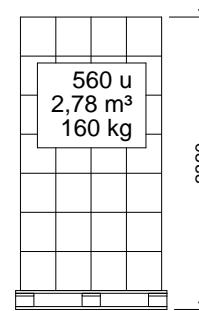

PESO PALET EUROPEO: 12 Kg.

PESO PALET AMERICANO: 24 Kg.

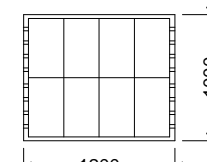
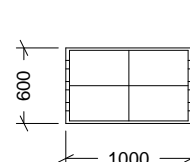

Cotas en mm