

NOMBRE

COMEDERO DE PEDAL

REFERENCIA

11345

CARACTERÍSTICAS DE PRODUCTO

MATERIAL

ACERO GALVANIZADO

COLOR

CHAPA GALVANIZADA

PESO

1,800 kg

VOLUMEN

-

ACCESORIOS



CROQUIS

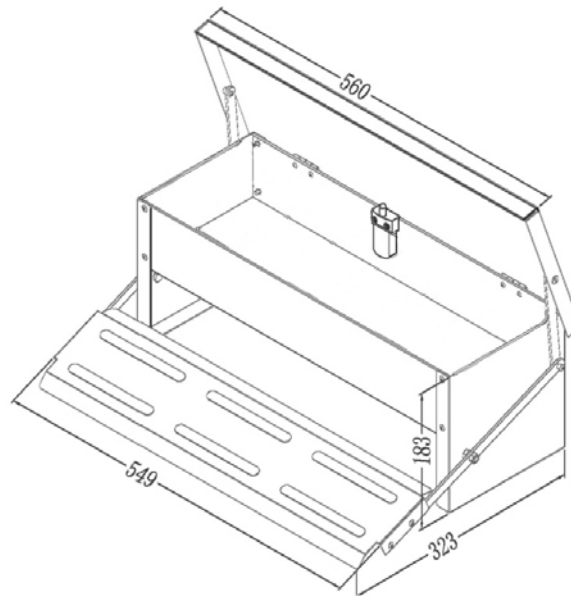

CARACTERÍSTICAS DE EMBALAJE

TIPO DE PACKING

CAJA

CANTIDAD

1 Unidad

DIMENSIONES

620x265x125 mm

PESO

2,200 kg

VOLUMEN

0,021 m³

PALET EUROPEO

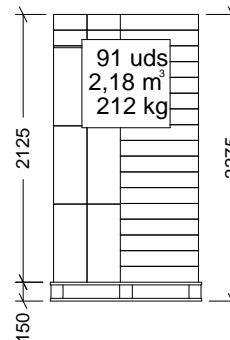

PALET AMERICANO

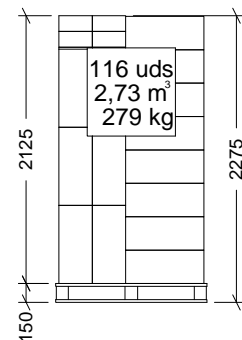

PESO PALET EUROPEO: 12 kg

PESO PALET AMERICANO: 24 kg

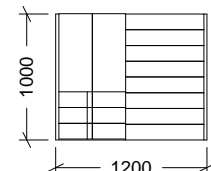
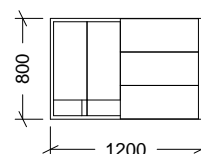

Cotas en mm