

NAME

**PREMIUM DRINKER 5 LITRES WITH PLUG (GREEN)**

REFERENCE

**11060**

**PRODUCT FEATURES**

MATERIAL

POLYPROPYLENE

COLOR

GREEN - WHITE

WEIGHT

0,545 kg

CLOSURE TYPE

SCREW CLOSURE

ACCESSORIES



SKETCH

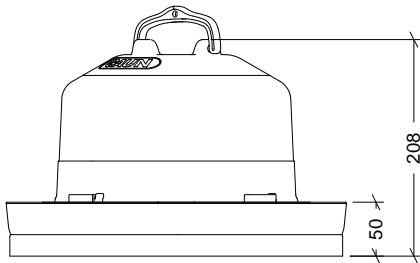

EXPLODED VIEW

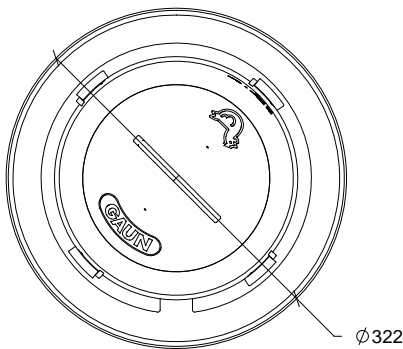

Nº	DESCRIPTION
1	DRAIN PLUG
2	O-RING
3	BASE
4	CONTAINER
5	HANDLE

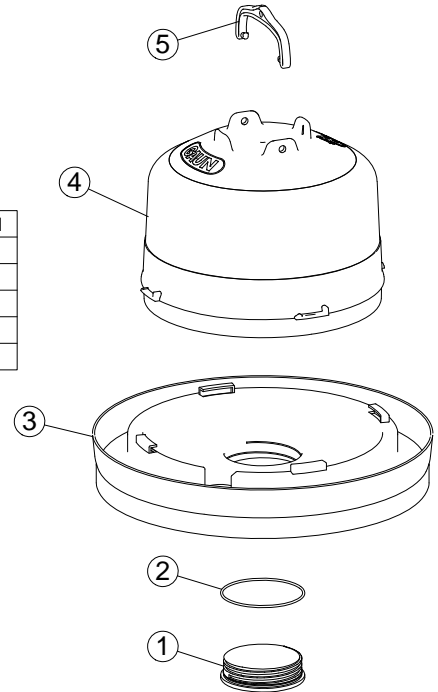

**PACKAGING FEATURES**

PACKAGING TYPE

BOX

UNITS/PACKAGING

5 Units

PACKING DIMENSIONS

325x325x505 mm

PACKING WEIGHT

3,600 kg

PACKING VOLUME

0,053 m<sup>3</sup>

EUROPALLET

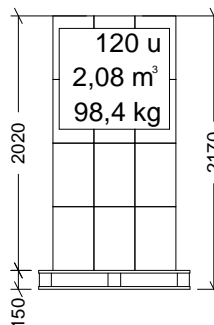

AMERICAN PALLET

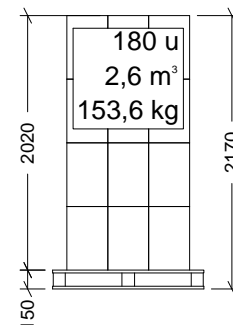

**EUROPALLET WEIGHT: 12 kg**

**AMERICAN PALLET WEIGHT: 24 kg**

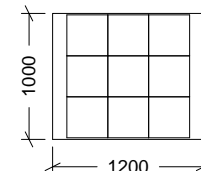
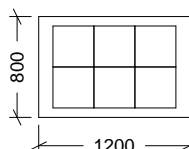

Dimensions in mm