

NAME

PREMIUM DRINKER 8 LITRES WITH PLUG (GREEN)

REFERENCE

11061

PRODUCT FEATURES

MATERIAL

POLYPROPYLENE

COLOR

GREEN - WHITE

WEIGHT

0,650 kg

CLOSURE TYPE

SCREW CLOSURE

ACCESSORIES



SKETCH

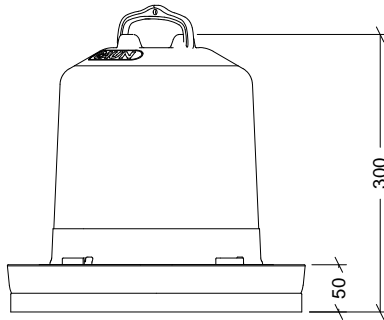

EXPLODED VIEW

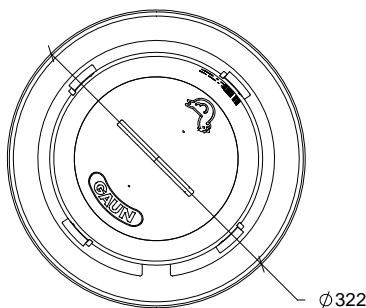

Nº	DESCRIPTION
1	DRAIN PLUG
2	O-RING
3	BASE
4	CONTAINER
5	HANDLE

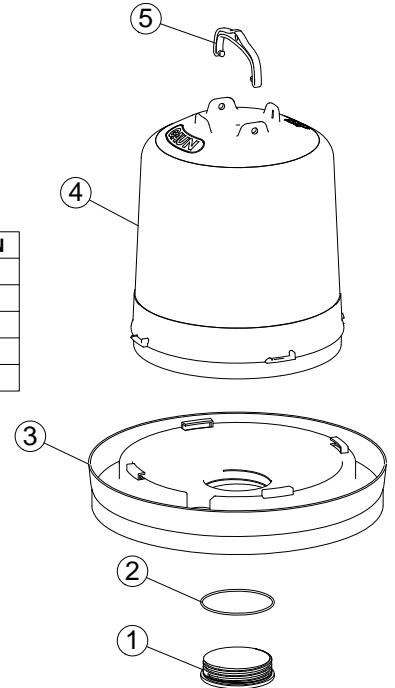

PACKAGING FEATURES

PACKAGING TYPE

BOX

UNITS/PACKAGING

5 Units

PACKING DIMENSIONS

325x325x610 mm

PACKING WEIGHT

4,300 kg

PACKING VOLUME

0,064 m³

EUROPALLET

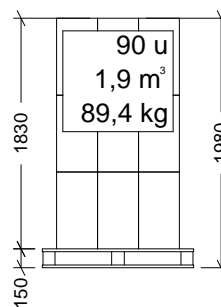

AMERICAN PALLET

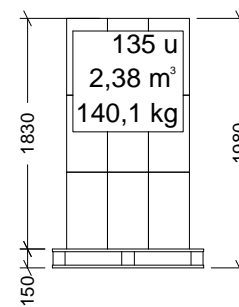

EUROPALLET WEIGHT: 12 kg

AMERICAN PALLET WEIGHT: 24 kg

